

COLLET ER20
DIN 6499-L32

M6-6H per n°6
thread = 6 mm
holes = 8mm
sm.0,5

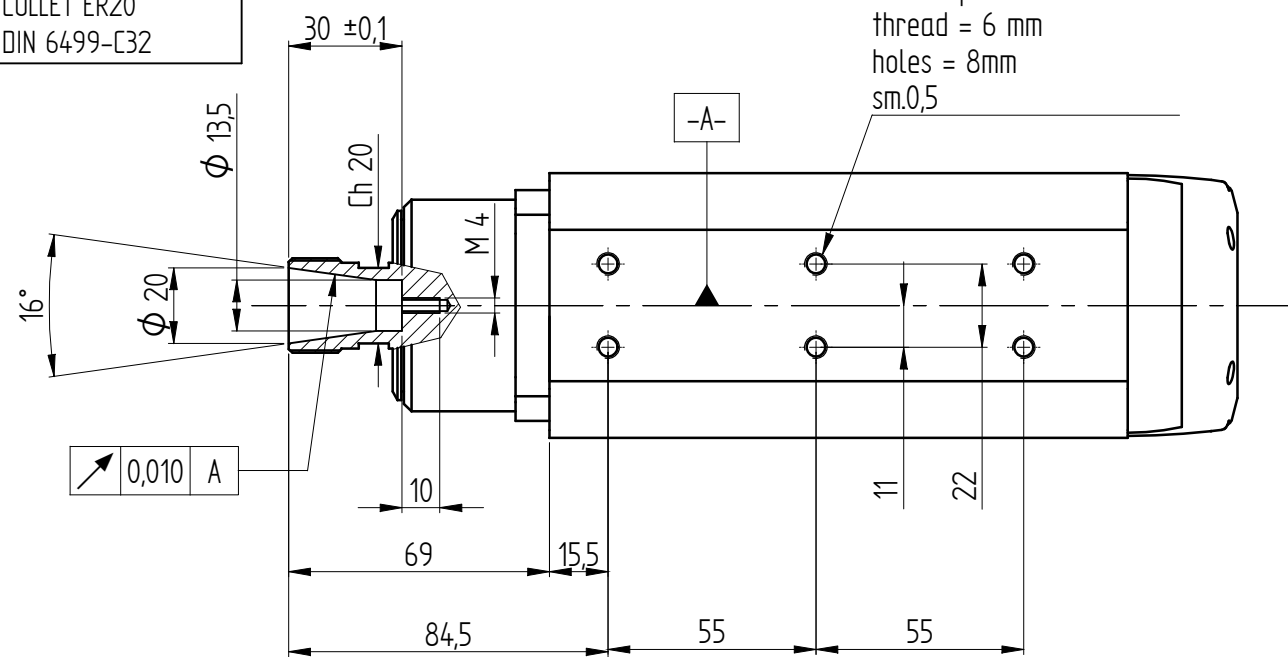

0,010 A

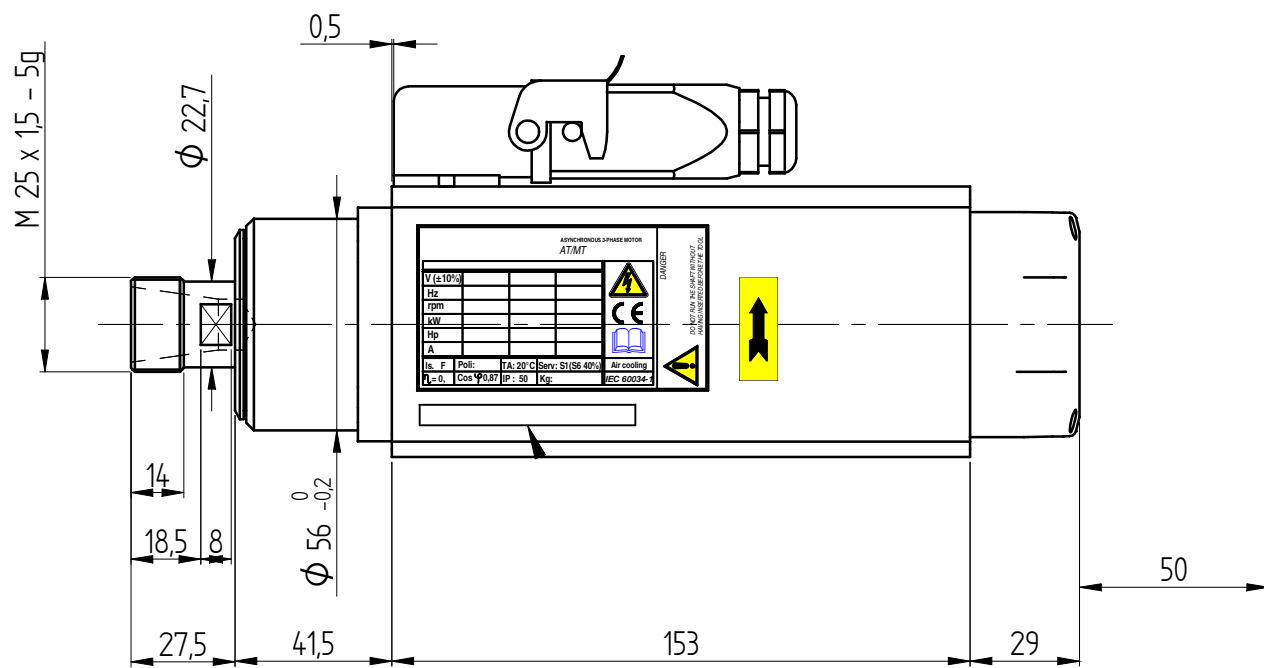

251

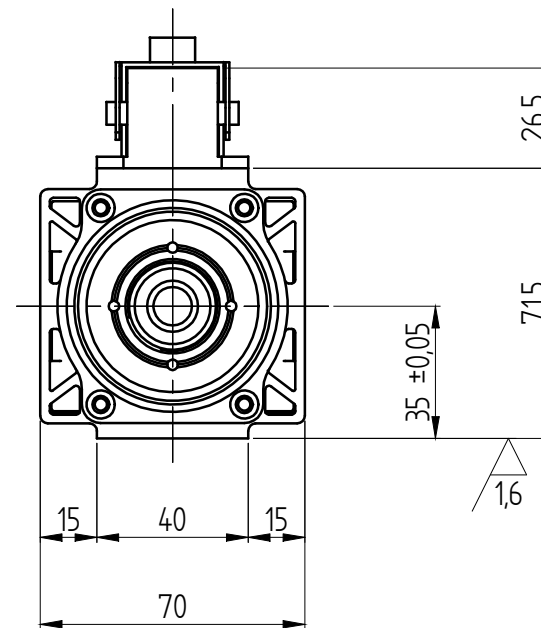
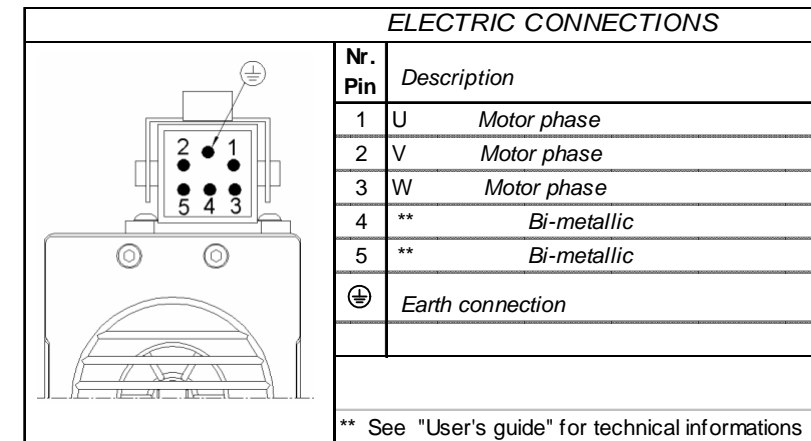
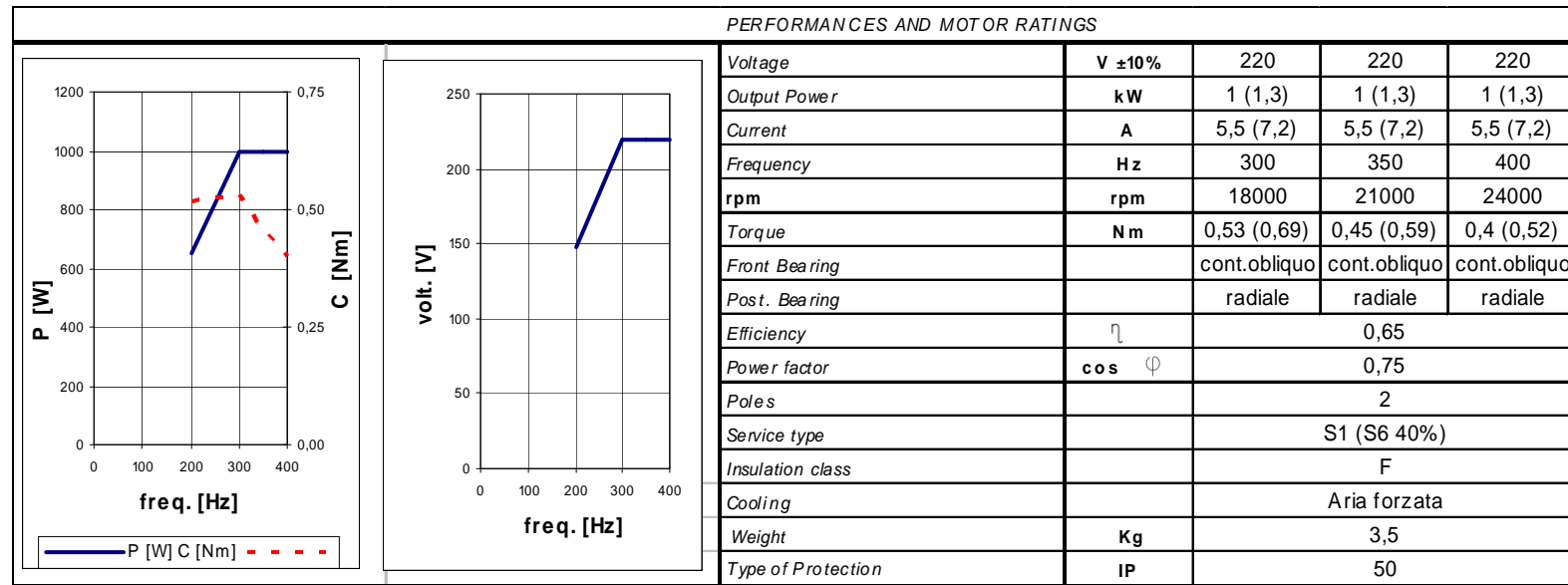
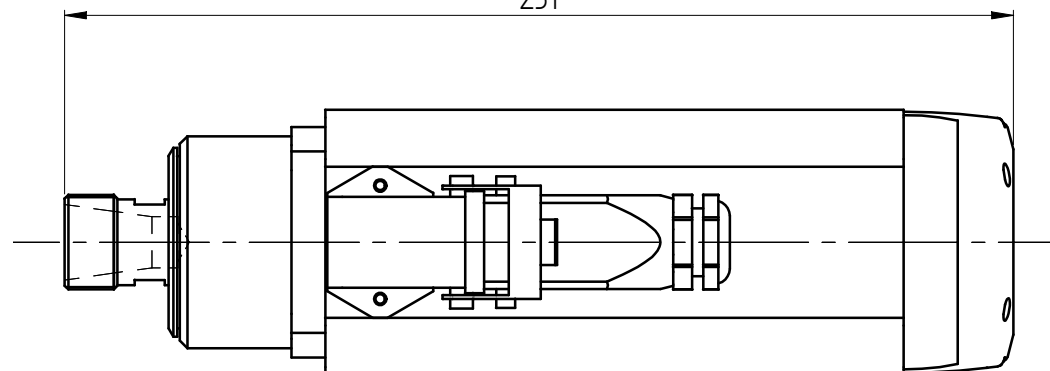

ELEKTROMOTOREN.DE
World in Motion

1		10/01/08	L.B.		A3
REV.		DATA	FIRMA		
DATA		SCALA: 1:2		22768-1f UNI-ISO 22768-2H	
FIRMA					
				1	
A#5560_MT1055-090-ER20-220V-DX-18/24000-1KW S1				Y6162Y0005	